

AEROREPORT 02|17

The aviation magazine of MTU Aero Engines | www.aeroreport.de



Tried-and-tested technology

*MTU's unique testing expertise
spans many areas*

MARKET

The multifaceted world of accessories

PARTNERS

A collaboration spanning decades ensures safe flight operations for German Armed Forces

EXPERTISE

ISABE 2017: Future trends for air-breathing engines



Almost like being in a cockpit — In the test cell control room for the A400M transport aircraft's TP400-D6 engine at MTU Maintenance Berlin-Brandenburg.

Dear readers,

In the aero engine industry, we are rarely as close to our final product as we are during a test run. Just as in the cockpit of an aircraft, a thrust lever in the control center is used to start up the engine. This engine is fixed to the ceiling of an impressive test facility and is now generating enough thrust to launch a passenger jet.

But even in this area, digitalization is making its mark and bringing about developments that we would have considered impossible a few years ago. These days, the thrust generated in the test facility is digitally controlled since the human hand is not capable of the same level of precision. We can also now evaluate an increasing number of component developments using computer simulations, thus avoiding the previous need for costly and time-consuming design, construction and testing work. Test runs of complete engines are—as yet—too complex for computer simulation.

With today's rapid advances in information technology, however, I don't want to rule out the possibility that we will reduce our use of the engine test cell in favor of computer simulations when it comes to the next generation of engines. We already use simulations today in the development of materials and manufacturing processes. We have also started to build "digital twins" of components; in other words, we collect and link all the information gathered in the "real" world about a given component, such as test run results, so that we can then predict the way it will behave.

In this issue of **AEROREPORT**, we tell you all about our development and production engines testing, taking a peek inside a test facility as we do so. In addition, we've asked two participants of this year's ISABE conference about trends and tendencies in the development of aircraft engines. We also delve into the world of accessory maintenance, present an unusual customer, and take a look at the future of supersonic passenger air travel.

Following my 12-year tenure as MTU Aero Engines' Chief Operating Officer, the time has now come for me to say farewell. I feel extremely fortunate and proud to have been a part of the Geared Turbofan™ technology development and many further innovations during that period. MTU has an outstanding future ahead, and I'll be remaining in close contact.



Happy reading.

A handwritten signature in blue ink that reads "R. Martens". The signature is fluid and cursive.

Dr. Rainer Martens
Chief Operating Officer



COVER STORY

Tried-and-tested technology

Although the use of computer simulations in the aviation industry is increasing rapidly, real engine and component tests remain essential. Over decades, MTU Aero Engines has built up a global test cell infrastructure, without which modern engine construction and reliable maintenance would be unthinkable.

pages 8–15



MARKET

Starters, pumps, sensors, valves

Engines come with hundreds of different accessories—making it all the more complex and demanding a task to maintain them quickly and reliably. Mastering the vast array of components really does pay off, though, as the prospering business of MTU Maintenance in Richmond near Vancouver testifies.

pages 20–23



PARTNERS

Why efficiency is key to BA CityFlyer

The 100 percent subsidiary of British Airways offers regional point-to-point connections as scheduled and leisure flights between London City Airport and destinations in Britain and Europe. Naturally, the aircraft and their CF34 engines must work perfectly at all times to manage the particularly high utilization rates of a regional route.

pages 24–27

CONTENTS

NEWS

- 6 **MTU raises earnings forecast** Financials Q3 2017
- 6 **Pioneers** MTU supports the A400M’s TP400-D6 engine
- 6 **Exclusive contract for CF34** MTU Maintenance wins new customer Air Burkina
- 7 **Green light for the V2500-A5** MTU Maintenance Canada becomes the third MTU site in the IAE network
- 7 **Among experts** MTU Aero Engines at the 66th German Aerospace Congress

COVER STORY

- 8 **Tried-and-tested technology** Over decades, MTU Aero Engines has built up a global test cell infrastructure
- 16 **Behind the scenes** A look at the testing procedure in an engine test cell

MARKET

- 20 **Starters, pumps, sensors, valves** Accessory repairs at MTU Maintenance Canada

PARTNERS

- 24 **Why efficiency is key to BA CityFlyer** The British airline is growing—and not only at London City Airport
- 28 **A collaboration of trust** For 45 years, the German Armed Forces have placed their trust in the Sikorsky CH-53G transport helicopter in partnership with MTU Aero Engines

EXPERTISE

- 30 **“The future is geared”** Interview with Dr. Frank Grauer, keynote speaker at the 2017 ISABE conference
- 36 **Working together around the globe** Interview with Dr. Rainer Walther, Administrative Secretary of ISABE
- 40 **A well-grounded assembly system** MTU employees develop a floor-based assembly concept for the PW1100G-JM

**PARTNERS**

A collaboration of trust

When there are heavy loads to be transported, or troops to be landed in hard-to-reach areas, a high-performance helicopter is an absolute must. For 45 years now, the German Armed Forces have been operating the Sikorsky CH-53G transport helicopter. And throughout, MTU Aero Engines has been at their side, taking expert care of engine maintenance.

pages 28–29

**EXPERTISE**

“The future is geared”

Dr. Rainer Walther, Administrative Secretary of the International Society of Air Breathing Engines (ISABE), and Dr. Frank Grauer, MTU's Director Engineering Advanced Programs, tell us about the worldwide exchange of knowledge about the future of air-breathing engines at this year's ISABE conference.

pages 30–39

**TECHNOLOGY**

The next supersonic generation

The supersonic passenger jet Concorde is history, but where is the future of fast passenger flights? **AEROREPORT** author Andreas Spaeth, who flew on the Concorde on several occasions, looks on three supersonic projects that are currently in development.

pages 42–45

TECHNOLOGY

42 **The next supersonic generation** Where does the future of ultrafast passenger flight lie?

FACTS

- 46 **From automobile mechanic to aviation pioneer**
Gerhard Neumann (1917-1997)
- 47 **Big and efficient** At GE Aviation, the GE9X is nearly ready for its first flight
- 48 **An aircraft's eyes and ears** Sensors and systems work together to ensure a safe flight
- 49 **30 years of the V2500** Facts and figures about the successful A320, MD90 and KC-390 engine
- 50 **At a glance** The GENx in numbers
- 50 **Masthead and photo credits**



www.aeroreport.de

All articles from the print edition are also available online at www.aeroreport.de, optimized for smartphone and tablet. There you find informative videos, photo galleries, zoomable images and other interactive specials too.

MTU raises earnings forecast

In the first nine months of 2017, MTU Aero Engines saw its revenues increase by 10 percent to **3,745.4 million euros**. The group's operating profit increased by 14 percent to reach 450.6 million euros, improving the EBIT margin from 11.6 percent to 12 percent. Earnings after tax rose by 17 percent to 320.4 million euros. "Based on these results and the positive effects on earnings that we now expect to derive from our product mix, we are able to raise our earnings forecast for this year," said

CEO Reiner Winkler. By year-end, MTU now expects adjusted EBIT to grow to around **600 million** and net income to reach around **420 million euros**. The company had originally forecast adjusted EBIT of around 560 million and adjusted net income of some 390 million euros. MTU has aligned its revenue forecast to reflect exchange rate changes and now expects to generate revenues of around 5.1 billion instead of around 5.3 billion euros.

Pioneers: MTU supports TP400-D6 engine for A400M

Over the next five years, MTU Aero Engines will support all engines powering Germany's Airbus **A400M** military transport aircraft. The maintenance framework agreement was concluded between the German Federal Office of Bundeswehr Equipment, Information Technology and In-Service Support (BAAINBw) and MTU. "As a result, Germany now has a comprehensive maintenance concept in place for the **TP400-D6**," says Michael Schreyögg, Chief Program Officer at MTU. "This makes us the first company with a certification based on commercial MRO techniques to repair the A400M engine." On-wing maintenance and repair tasks (Maintenance



Levels 1 and 2) are performed by the German Air Force, whereas more intensive services with **Maintenance Levels 2-OFF and 3** are contracted out to industry. New ground has been broken with the maintenance concept for the TP400-D6: although the engine powers a military

transporter and it is certified to commercial standards. The maintenance activities had to be set up accordingly, and the rules drafted as a result were integrated into the newly created European Military Airworthiness Requirements (EMAR). Their implementation is governed by the German DEMAR 145 repair specifications.

Exclusive CF34 engine maintenance contract

In summer 2017, **MTU Maintenance** and new customer **Air Burkina**, the national airline of Burkino Faso, signed an exclusive three-year maintenance agreement. The contract for the airline's four **CF34-8E engines** powering its **E170 aircraft** covers maintenance, repair and overhaul, on-site services and guaranteed spare engine leasing availability.

Air Burkina operates regional flights from the Burkino Faso capital Ouagadougou to other countries in Africa. It is MTU Maintenance's first CF34-8 customer in sub-Saharan Africa and one of its over 90 customers worldwide. MTU Maintenance has been maintaining engines from the CF34 family (CF34-3, -8C/E, -10E) for 15 years and performs **over 100 shop visits** for this engine type annually.

Green light for the V2500-A5



MTU Maintenance Canada is expanding its service portfolio: Transport Canada Civil Aviation has now given its approval for the Vancouver-based shop to maintain V2500-A5 engines. The decision that the MTU Maintenance site in Vancouver should perform MRO services for the **V2500-A5** within the IAE network until the program ends is the result of an agreement between the three partners, Pratt & Whitney, International Aero Engines AG (IAE) and MTU Aero Engines. At least 140 shop visits are scheduled in the first four years.

With a market share of approximately 35 percent, MTU Maintenance is currently the **number one MRO provider worldwide** for the V2500 engine, which powers aircraft in the A320 family. V2500 models are already maintained at the MTU sites in Hannover and Zhuhai. “With the build-up of V2500 expertise in Vancouver, we’re now strengthening our position in another core market besides Europe and Asia—namely, North America,” says Helmut Neuper, President and CEO of MTU Maintenance Canada.

Among experts

Topics of the future such as systems capability, modern propulsion technologies, unmanned and electric flying and robotics were the main subjects explored at the **66th German Aerospace Congress** at the Technical University of Munich in Garching. But the focus was also on the foundations that enable technological progress in these areas in the first place. In his plenary address, Dr. Gerhard Ebenhoch, Director, Technology Management at MTU, outlined two key technologies for future engine development: simulations and digitalization. “Simulation speeds up development and enables new approaches such as interdisciplinary optimizations and the use of probability-based analyses,” he explained. “To be able to turn the large volumes of data generated when processes are digitalized to profitable use, new, yet-to-be-developed analytical approaches are needed.”

The Wolfgang Heilmann Award, which MTU presents every year to acknowledge outstanding academic achievements by young talent, was won this year by Timon Jungh. In his bache-

lor’s thesis, the 23-year-old created a finite elements model for calculating film cooling variables. Making it as easy as possible to integrate the data into the evaluation chain was one of the focal points of the work.



Wolfgang-Heilmann-Preis _____ Dr. Gerhard Ebenhoch (front left) presented the prize awarded by MTU to Timon Jungh (front right) in Garching.



Tried-and-tested technology

Although the use of computer simulations in the aviation industry is increasing rapidly, real engine and component tests remain essential. Over decades, MTU Aero Engines has built up a global test cell infrastructure, without which modern engine construction and reliable maintenance would be unthinkable.

Text: Thorsten Rienth

Ready for testing — A PW1100G-JM, the engine powering the A320neo, in the test cell at MTU Maintenance Hannover.



Preparation for the test run
Air intake system and bellmouth mounted on a PW1500G at MTU in Munich.

“Acceptance tests are mandatory for all production engines.”

Kurt Scheidt

Senior Manager, Engine and Flight Test at MTU Aero Engines in Munich

Every step requires the same level of coordination as passing the baton in a relay race: Jack up the straddle carrier with the engine. Pass the bolts of the engine mounting through the openings in the thrust measuring bridge. Hook up the multicoupling system, which allows not only the engine measuring points and test cell measurement system, but also the control and supply lines, to be connected with a single click. All the technicians have to do now is mount the air duct—which thanks to the new quick lock takes a matter of minutes. Then the bellmouth clicks into place like a lens on a camera. While testing gets underway inside, the technicians in the pre-rigging room are getting the next engine ready. And next door, they are packing up the engine that has just come off the test cell.

The processes are tuned for speed. Test cell capacities are precious, and the program volume at MTU Aero Engines in Munich is high: once the Pure Power® PW1100G-JM engine assembly is completely ramped up at the site by the end of 2018, almost one A320neo engine a day will undergo production acceptance testing on test cell 3.

“Acceptance tests are mandatory for all production engines,” explains Kurt Scheidt, who heads up MTU’s engine testing in Munich: without proven performance parameters, no engine will be issued an airworthiness certificate. And that depends on the measurement data produced in an acceptance test run.



Everything under control — Test cell control room at MTU in Munich. Nowadays, the computer is responsible for “running” the engine with the thrust lever, as its movements are more precise than the human hand.

Computer control instead of the human touch

The control center looks like the space operations center from a blockbuster movie: meter-high switchgear cabinets with whirring ventilation systems, knobs, controls and thrust levers recessed into tables and consoles. Add to the mix dozens of monitors displaying all relevant information graphically enhanced and collated in real time. Exhaust temperature, airflow, generated thrust, fuel consumption. On other screens, cameras reproduce every square centimeter of the test cell. For safety reasons, it's seldom possible these days to view the test engine directly from the control center, and if it is, then only behind centimeter-thick bulletproof glass.

The thrust lever for “running” the engine is also becoming a rarity, because no human hand can match the precise control achieved by a computer. And only when the entries are absolutely identical are the test results considered actually reproducible.

It can take years before a new test cell is ready for operation

The planning, construction and calibration of test cells is a time-consuming business. “Setting up a new test cell can quickly run into years,” explains Thomas Michaelis, senior manager, engine testing, at MTU Maintenance Hannover. “This makes it

all the more important to take a farsighted approach.” When a good ten years ago planning for a test cell for large engines in Hannover began, the focus was on the GE90-115B with its 115,000-pound thrust. Nevertheless, the planners designed the test cell for thrusts of 150,000 pounds—to literally give them some excess power. “That will pay off when we’ll have to start accommodating the GE9X in our maintenance facilities in a few years’ time.”

The thrust class is not the only relevant factor when constructing a test cell, however. The engine mounting in the test cell is comparatively easy to exchange for a more powerful system, Michaelis says. “The crunch is the maximum airflow.” For a GE90-115B running at full capacity, this is more than three metric tons a second. “First of all, I have to get this volume of air into the test cell—and out again on the other side.”

The blade tips speed past sensors at up to 500 meters a second

While OEM (Original Equipment Manufacturer) production acceptance tests and the test runs for overhauled engines are similar, development tests have a different focus altogether: they are used to validate new technologies or complete engine modules for future use.

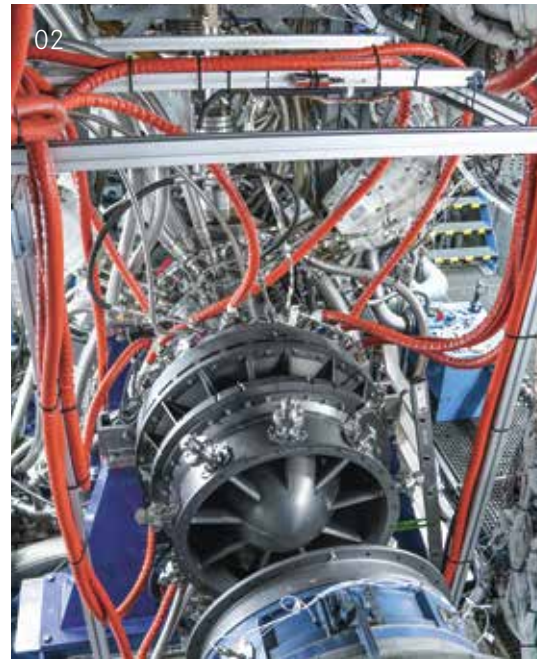
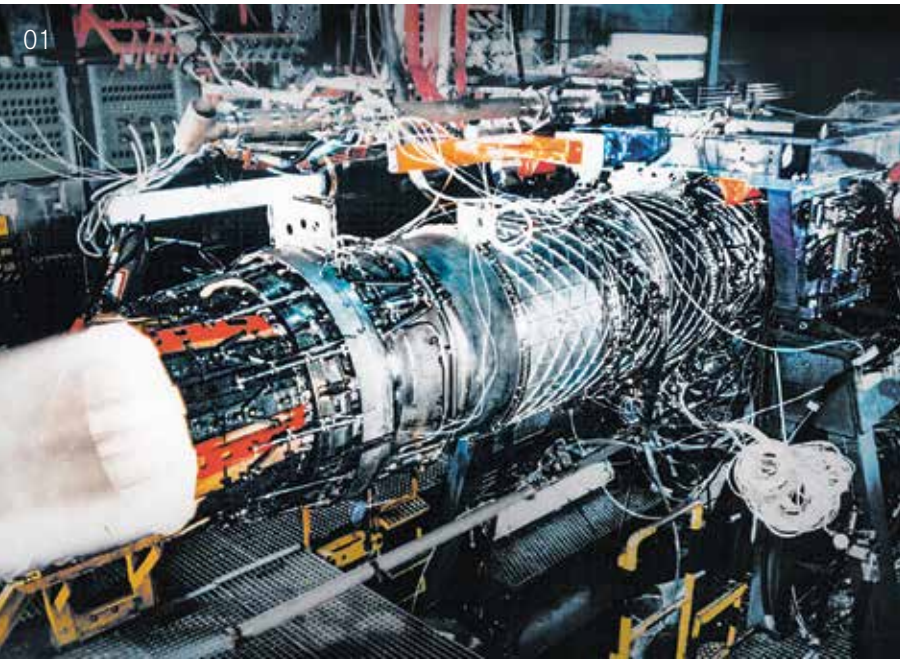

- 01** ____ *An EJ200, the engine that powers the Eurofighter, on the test cell with ignited afterburner.*
- 02** ____ *Components and development assemblies are also tested. Pictured is a compressor rig, used to test technological developments for the PW1100G-JM at MTU in Munich.*
- 03** ____ *Once repaired, each engine has to demonstrate on the test cell that it fulfills the requisite performance parameters again; pictured is a V2500 at MTU Maintenance Hannover.*
- 04** ____ *The only test cell in Germany for the A400M transport aircraft's TP400-D6 engine is found at MTU Maintenance Berlin-Brandenburg.*

In such cases, test cells resemble a precision engineering workshop: bundled together like a huge bunch of long, thin grasses, hundreds of wires snake out of compressors or turbines. Their ends are rolled up with two or three rotations. Small stickers indicate which sensor the cable is attached to. The measuring points consist of conventional sensors, vibration transducers and resistance strain gauges. The latter are wafer-thin metal strips,

through which electric current is passed during the tests. They measure any changes in resistance, however infinitesimal, resulting from the expansion of the metal strips when the engine component expands, whether heat-induced or caused by centrifugal forces. However, this is sufficient for the computer to be able to identify which current change corresponds to which strain. At the same time, an extremely accurate time measurement system

is installed. The blade tips fly past the sensors at speeds of up to 500 meters a second.

The wiring must be carried out extremely carefully—meticulously, even. It's not uncommon to have to connect up over 1,000 measuring points—often also on rotating parts. All of these have to be wired painstakingly by hand. Without a precise overview, the whole structure is worthless. Depending on the complexity, the setup alone can take an entire year.

Engine lifecycle in fast motion

Because no two development tests pursue the same objectives, every setup is unique. During endurance testing on the PW1500G last year, for example, the engineers ran the C Series engine through the engine lifecycle in fast motion. They designed the 13-minute test cycle—consisting of takeoff, cruising and landing—so that after 10,000 cycles, the high-pressure turbine had reached 70 percent of its projected service life. Another focus of the tests was validation of additional engine externals at maximum permissible load—which is twice the permissible load of a new engine. To enable them to generate this, the engineers use a trick: they install balancing weights. The test ran for half a year in two- and three-shift rotation, interrupted only every 500 cycles for borescope inspections.

“Even in simple tests, the interactions between the individual engine systems and modules become extremely complex.”

Kurt Scheidt

Senior Manager, Engine and Flight Test at MTU Aero Engines in Munich

Given the rapid development of simulation software, why aren't tests carried out virtually? “Of course it's possible in the meantime to represent individual tests virtually,” Scheidt says. However, he believes complete engine tests are much too complicated to be run on the computer any time soon. “Even in simple tests, the interactions between the individual engine systems and modules become extremely complex.” How is the software to map a hail strike that also has to be verified? “I also doubt whether the authorities would issue an airworthiness certificate for an engine that has only been tested virtually.” And even if they did: would passengers want to fly in an aircraft powered by such engines?

Test cells for decades

It therefore appears likely that MTU will continue to operate test cells at its sites. In some cases, completely new test cells are set



Foundations laid — A test center for engine components is currently being built at MTU in Munich.

New component test center

Completion of the new component test stand next year marks the next major investment at MTU's headquarters in Munich. In the component testing center there, the developers will be able to apply and even combine around 70 testing methods. The centerpiece of the new testing center is a tandem spin test stand in a double-shell reinforced concrete structure. There is a very good reason for this encasing: if one of the parts breaks while spinning, it can create a force equivalent to a VW Golf driving into a wall at 60 kilometers per hour. A vibration test facility allows parts to undergo extensive testing for their vibration resistance, a firing facility fires steel balls at turbine blades and for structural testing, the developers can subject the component structures to physical loads using hydraulic pistons.

up, in others older ones are updated. Test cell 1 in Munich was originally an afterburner testbed for military programs; later the PW6000, CF34 and PW1200G engines ran on it, for example. Test cell 12, currently scheduled for the T408 engine to power the Sikorsky CH-53K, was previously used for a development program running extensive tests such as bird strike and sand injection. And test cell 3, which now runs the production acceptance tests for the PW1100G-JM engine, is where MTU used to conduct development tests on large engines of higher thrust classes, such as the GP7000 powerplant for the Airbus A380. ✈️



Impressive _____ A PW1100G-JM on the test cell at MTU Maintenance Hannover.
One third of all PW1100G-JM engines worldwide are assembled at MTU and then tested
at its facilities in Munich and Hannover.

Presence in Asia



Flexible _____ *The test cell at MTU Maintenance Zhuhai is calibrated for the V2500 and for three CFM56 variants.*

270 engines a year pass through the shop at MTU Maintenance Zhuhai, the arm of MTU Maintenance in Asia—and hence also through the test cell there. This is currently calibrated for the V2500 and the -3, -5 and -7 variants of the CFM56. “This allows for flexible test procedures,” President and CEO Frank Bodenhage explains. “While a ‘-5’ is being worked on in the pre-rigging room, a ‘V’ is running in the test cell and a ‘-3’ is being de-rigged.” The wide variation on the one hand makes planning challenging, he points out. “We have to keep the test cell permanently calibrated for all programs.” On the other hand, the processes in Maintenance also help the planners: “If I’ve got an engine in the shop, I can say fairly exactly when the test cell will be vacant and require calibrating accordingly.”

Testing at MTU Maintenance Canada

Engines do not just consist of compressors and turbines, but also of a large variety of accessories such as starters, fuel pumps and measuring instruments, as well as hydro-mechanical components. MTU Maintenance Canada specializes in repairing them (see also “Starters, pumps, sensors, valves” article on page 20 of this issue). Before the accessories are delivered back to the customer, they also have to undergo acceptance testing on the test cell. The test facilities in Vancouver are therefore particularly diversified, with a separate test stand each for actuators, fuel pumps and fuel measuring instruments. The latest addition to the family, in operation since early 2017, is the starter test stand. The MRO engine test cell also located on site is currently calibrated for the CFM56-3 and CF6-50 programs. At the same time, it is being calibrated for the V2500, which will soon be added to the location’s portfolio.



Variety _____ *In addition to an engine test bench, MTU Maintenance Canada also possesses test cells for accessories such as actuators, fuel pumps and starters.*



Do you have any questions, requests or suggestions?
Contact the editors here: aeroreport@mtu.de



More on this topic: www.aeroreport.de



Text:

Thorsten Rienth writes as a freelance journalist for **AEROREPORT**. In addition to the aerospace industry, his technical writing focuses on rail traffic and the transportation industry.

Behind the scenes

A look at the testing procedure in an engine test cell.

Text: Thorsten Rienth

Chart: Peter Diehl

Engine test runs are choreographed procedures that, while being easily plannable, require a large number of different activities depending on the purpose of the test.

A development test run is intended primarily to validate theoretical assumptions in practice. To this end, components are sometimes deliberately subjected to loads that normally do not occur in conventional flight operations.

Due to the individual instrumentation and many measuring points, rigging is usually a time-consuming business.

Production acceptance tests on new or freshly overhauled engines on the other hand verify clearly defined performance parameters. They can be carried out considerably faster, because the engine and test cell are connected up using interfaces that can be quickly coupled. MTU's

Munich site handles one third of the PW1100G-JM acceptance tests on new engines. MTU Maintenance Berlin-Brandenburg in Ludwigsfelde is responsible for production acceptance tests on all TP400-D6 engines destined for German A400M transporters.

But whatever test is due to be carried out—the steps the engine goes through in the test cell are always the same.

06

10

08

De-rigging

Once the engine and test cell are decoupled after the test run, the technicians start the de-rigging process. This promptly frees up the test cell for the next engine.

09

Delivery

After final inspection, packing and completion of formalities, a tested engine sets off on its travels again—either back to the airline or directly to the aircraft manufacturer's final assembly line.

10

Fuel supply

Where engines are tested, kerosene is needed, Jet A-1 fuel to be precise. The tank that supplies the test stands in Munich has a capacity of 100,000 liters.



More on this topic: www.aeroreport.de



Do you have any questions, requests or suggestions?
Contact the editors here: aeroreport@mtu.de



Text:

Thorsten Rienth writes as a freelance journalist for **AEROREPORT**. In addition to the aerospace industry, his technical writing focuses on rail traffic and the transportation industry.



01 *Arrival*
No engine arrives unscheduled at a test stand from the wing or a final assembly line. This facilitates planning of human resources and test stand times or the provision of the equipment needed for the respective tests due to be carried out.

02 *Pre-rigging room*
To enable the engineers to verify and test as many engines in the test stand as possible, they keep the rigging to a minimum. For all work on the engine that does not have to be performed directly in the test cell, they use the pre-rigging room. This is usually large enough to allow up to three engines to be rigged up at once.

03 *Air duct*
Behind the gigantic sliding doors at the air duct, bird screens and interceptors, for example for pebble stones—and a sound absorber—are hidden.

04 *Starter air tanks*
In the test cell, it's not possible for engines to power themselves up using the start-up process. For this reason, compressed air—supplied from starter air tanks—is used to help set the engine running.

05 *Test cell*
The test cell is the centerpiece of every test cell. Connected physically with the thrust measuring bridge and digitally with the test bench software, this is where the actual test run takes place. The acceptance test run for a newly assembled or freshly overhauled engine is usually made up of simulated takeoff, cruising and landing sequences. The test cell is large enough to accommodate the additional infrastructure needed for development test runs, such as firing facilities for hailstones or jets for simulating torrential rain.

06 *Air outlet system*
Before the exhaust air is released into the environment, it has to pass through a sophisticated system of exhaust filters and sound absorbers.

07 *Control center*
This is the digital home and nerve center for the test engineers. From here, they control and monitor the tests. A large, bullet-proof window gives them a direct view of the engine. In the future, however, this will be replaced by a digital system using cameras and without an additional window.

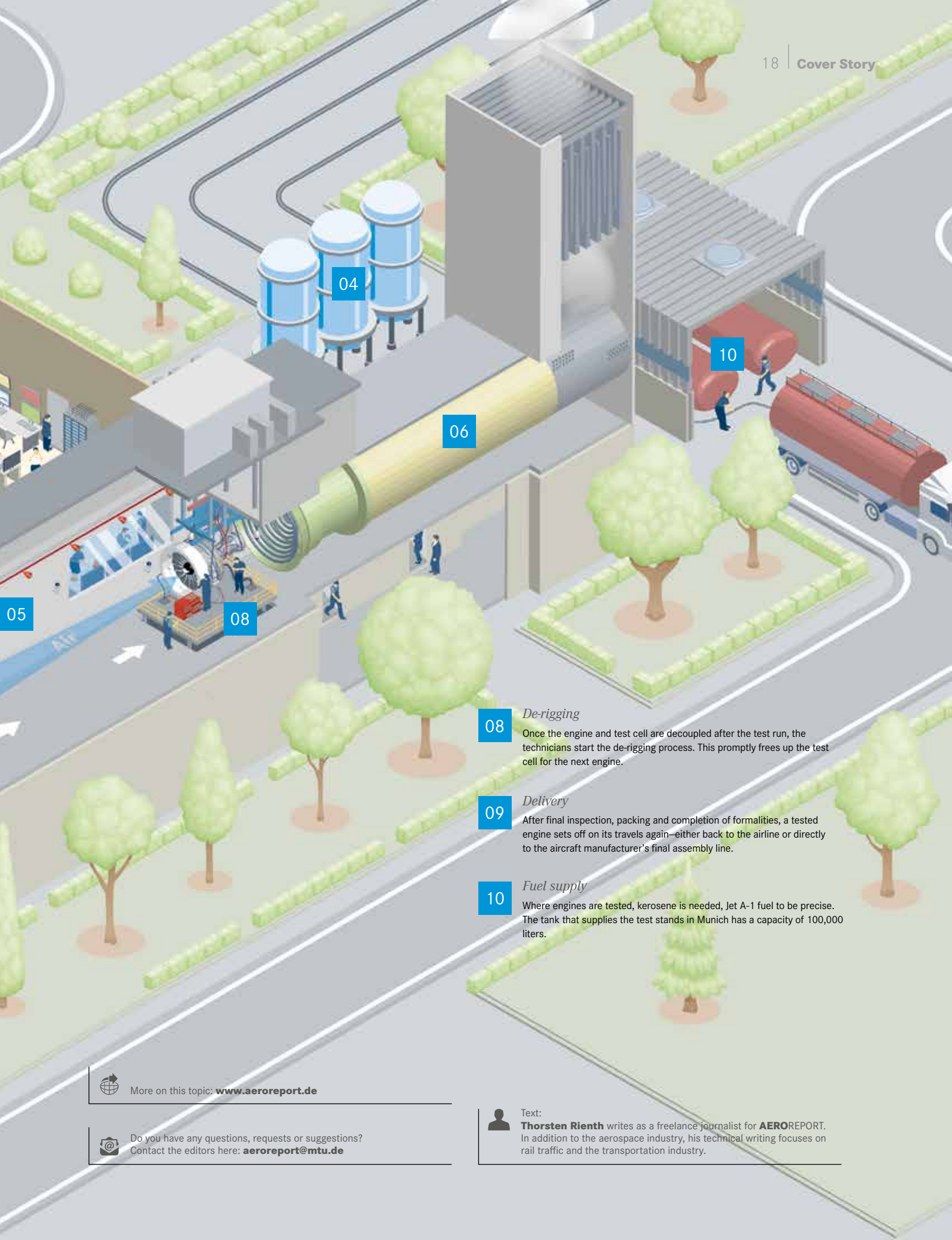

05

08

04

06

10

08

De-rigging

Once the engine and test cell are decoupled after the test run, the technicians start the de-rigging process. This promptly frees up the test cell for the next engine.

09

Delivery

After final inspection, packing and completion of formalities, a tested engine sets off on its travels again—either back to the airline or directly to the aircraft manufacturer's final assembly line.

10

Fuel supply

Where engines are tested, kerosene is needed, Jet A-1 fuel to be precise. The tank that supplies the test stands in Munich has a capacity of 100,000 liters.



More on this topic: www.aeroreport.de



Do you have any questions, requests or suggestions?
Contact the editors here: aeroreport@mtu.de



Text:

Thorsten Rienth writes as a freelance journalist for **AEROREPORT**. In addition to the aerospace industry, his technical writing focuses on rail traffic and the transportation industry.

Starters, pumps, sensors, valves

Engines come with hundreds of different accessories—making it all the more complex and demanding a task to maintain them quickly and reliably.

Text: Denis Dilba



Rarely in the spotlight alone _____ *The fuel-cooled oil cooler is one of the 80 different accessories there are on average in a V2500.*

If you imagine an aero engine—with its compressors, turbines and combustor—as a human heart, then its accessories could be likened to the coronary blood vessels. Just as the human heart is surrounded by a network of arteries, the engine is surrounded by a range of supporting components. The analogy continues: accessories are split into numerous component groups that are critical to the functioning of the whole, as in the human heart. Should these accessories fail, the engine is at risk of suffering something akin to a heart attack: the engine can no longer operate safely and the aircraft must either perform an emergency landing or else remain grounded. Meanwhile, the costs incurred increase with every passing minute.

Christian Ludwig and his team are there to do all they can to avoid such a scenario. “And if it does happen, we’re the ones who can get the aircraft back in the air the fastest,” says the Director of Accessories Operations at MTU Maintenance Canada in Richmond. Here, right on the doorstep of Vancouver and its international airport, MTU has established its Accessory Repair Centre of Excellence (A.R.C.). Initially, the plan was simply to agglomerate accessories activities within MTU but, as the company continued to invest in the personnel and infrastructure required for accessories repair, it quickly saw the opportunity to turn it into its own, effective business.



“The biggest challenge when it comes to accessories is the enormous complexity involved.”

Extreme complexity

“The biggest challenge when it comes to accessories is the enormous complexity involved,” says Ludwig—a level of complexity that only a select few in the market have a handle on. One single engine has an average of 80 different accessories, manufactured by 15 to 20 different suppliers. The array of components ranges all the way from starter motors, fuel pumps, hydraulic pumps, actuators, sensors, and valves all the way to wiring harnesses and tubing. “When you’re catering to all sorts of different engine types, like we are, it quickly amounts to a bewildering array of hundreds of different accessories that you have to manage,” says Ludwig. Just the logistics of gathering together the individual parts required to repair a wide range of accessories is an enormous task in itself.

On top of that, you have to factor in the range of geographic and time constraints that come into play when you have repairs to be carried out, and you need to have experts on hand to do the job. “For instance, if an airline is flying to Hawaii and experiences a leaking fuel pump, they will need an operational replacement as soon as possible,” says Ludwig. “At the same time, we need to reserve enough capacity to deal with maintenance and repairs on engine accessories that come in as part of a scheduled engine shop visit.” Then there are accessories that need to be checked

Christian Ludwig
*Director of Accessories Operations at
MTU Maintenance Canada in Richmond*

after a set number of hours in service. “We have to be able to cover all that work at the same time, or else our customers will lose interest,” says Ludwig.

450 repair procedures

Accordingly, the accessory repair process has to run like clockwork. “When an accessory comes in, an incoming test shows us what isn’t working. Then we take the unit apart and give it a good clean before we perform visual inspection and tests on the components,” explains Ryan James, who is responsible for engineering at the A.R.C. Repairs are then carried out, followed by re-assembly and final testing, before the accessory is sent back to the customer. Repairs draw on some 450 different procedures. And if the repair work is taking too long, James’s colleagues will simply take a complete, functioning unit of the same model from storage, and send that back instead.

As a result, defective accessories can be replaced with functioning ones within between four and 24 hours. “With some airlines, we have agreements to keep replacement units for their fleets in central storage. From there, the units are put onto the next aircraft to land at the airport where the exchange is due to take place,” says James. “That’s when we achieve the four hour replacement rate.” But even the 24-hour turnaround time is often

Inside MTU — *Accessory expertise and all-inclusive service*



Accessories are the range of components that surround the engine itself. This encompasses several hundred different components, which are divided into various subclasses according to their function. Fuel pumps, for instance, belong to the “fuel” category. Cable harnesses, on the other hand, belong to the “electrics” category together with the main engine controller (MEC). Other subclasses include “pneumatics”, “mechanics” and “oil.” To cater to the various accessory subsystems, MTU Maintenance Canada has developed several of its own test cells, which allow it to test accessories quickly and independently. Word of MTU’s expertise and flexibility in accessories maintenance has spread far and wide. Customers including for example the Mexican airline Volaris have been particularly attracted to MTU’s all-inclusive service package for accessories. In this case, MTU takes care of all an airline’s accessories, regardless of the engine type. It is quite simply the ultimate in accessory service.

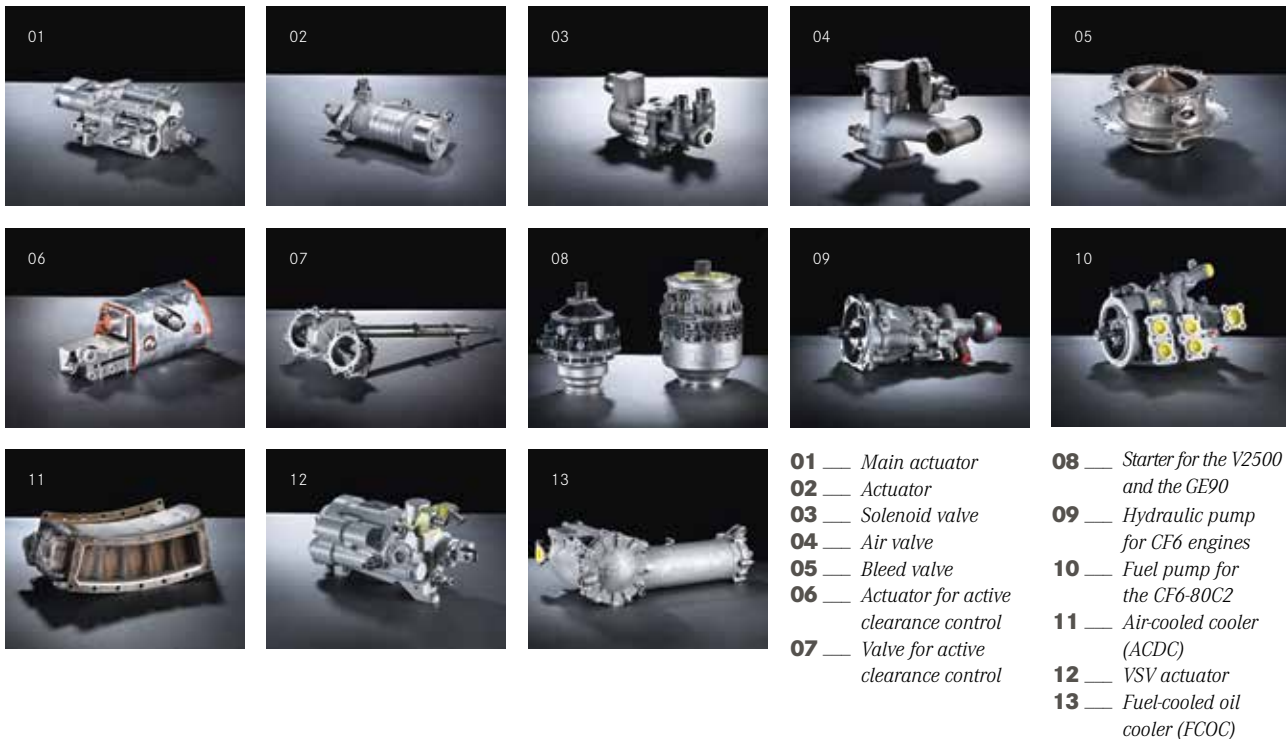

faster than what the competition can offer, competition that includes companies such as Lufthansa Technik, Allen Aircraft, AJ Walter and Triumph, as well as the manufacturers of the accessories themselves. The latter in particular often specialize in just a few accessories, and are slower in the decision-making process because of the size of their company. This means that they are rarely able to match the service offered by MTU's A.R.C.

All-inclusive service package for accessories

The Canadians are also extremely flexible, offering accessory repairs for everything from business jet engines such as the CF34-3 to the mighty GE90 that powers the Boeing 777. "Our all-inclusive service package for accessories is particularly popular," says Ludwig. This is a comprehensive service whereby

MTU takes care of all an airline's accessories. This includes the management of line replaceable units (LRUs), specific accessory components that can be replaced on location during routine operations. "This demanding service offering is possible only because around half of our employees in this segment work on site with the customer," says Ludwig.

Everything points to growth. Last year, the A.R.C. repaired 11,000 accessories, bringing in business amounting to 60 million Canadian dollars. The 98 members of the A.R.C. team currently serve 114 customers, which include airlines, engine manufacturers and even the U.S. Air Force. "We've set our sights on almost doubling our revenues by 2020," says Ludwig. In other words, business is booming. 



Do you have any questions, requests or suggestions?
 Contact the editors here: aeroreport@mtu.de



More on this topic: www.aeroreport.de



Text:

Denis Dilba holds a degree in mechatronics, is a graduate of the German School of Journalism, and founded the "Substanz" digital science magazine. He writes articles about a wide variety of technical and business themes.

London skies _____ *Regional airline BA CityFlyer, a British Airways subsidiary, has its headquarters at London City Airport, right in the heart of the metropolis.*



Why efficiency is key to BA CityFlyer

The joys and challenges of operations at UK-based regional airline BA CityFlyer.

Text: Victoria Nicholls





Mark Leather prefers the window seat to the aisle. He likes to be placed at the front of the plane, and never puts his seat back. Leather is professional and considerate. A lot like BA CityFlyer, the airline he works for as Head of Fleet and Airworthiness. BA CityFlyer is a premium airline. “Customers rely on us for top-quality service, great on-time performance and regularity,” Leather states, “criteria we always endeavor to fulfil.” The wholly-owned British Airways subsidiary is a point-to-point regional operator in the IAG consortium and provides scheduled and leisure flights in the UK and Europe. The operator carried nearly 2.2 million passengers in 2016, 13.4 percent more than in 2015 and a record number for the airline.

BA CityFlyer currently operates 20 Embraer 170s and 190s, having transitioned from RJ100s under Leather’s watchful eye in 2010. “Our entire fleet is under ten years old,” he states, adding that the company takes pride in its appearance and the cleanliness of its planes. Both Embraer aircraft are single aisle and have four seats per row.

Customers value punctuality and service more than low-cost tickets

“We have generous seat pitchings and highly-trained, polite staff. Customer satisfaction is everything to us,” Leather says. Even in a market where passengers are used to compromising service expectations for low-cost prices? “Especially then. We tend to get very high customer feedback scores. Because customers appreciate our punctuality, and also our service from check-in on the ground and at gate areas through to the service on the plane itself.” The regional operator has two classes, the business class “Club Europe” and the economy class “Euro Traveller.” Passengers in both categories are not charged for checked-in luggage and receive complementary meals or snacks respectively.

Challenging London City Airport

London City Airport is the airline’s main base and convenient for business people and tourists alike. “It’s in the center of London by Canary Wharf, accessible and easy to use. Check-in times are much shorter here, too,” Leather says. Of course, operating out of London City does not come without challenges. There is very limited space and no hangars. And at 5 degrees, the approach to land is pretty steep due to obstacles and building clearance. Only the captain may land the plane. This is significantly higher than the international standard of 3 degrees, which can be landed by first officers too. Heathrow, for instance, is currently trialing a 3.2 degree approach with the aim of increasing to 3.5 degrees at a later date.

Additionally, London City closes for a 24-hour period during the weekend. Previously, BA CityFlyer would operate charter flights from other UK airports to better utilize the fleet during this time. But the strategy has changed. Now, the airline offers scheduled leisure flights from London Stansted over the weekends too during the summer. Furthermore, Birmingham, Bristol, and Manchester were recently added as weekend bases. “We’ve been flying our aircraft a lot more actively this summer,” Leather says. Utilization is particularly important to the airline. “Regional operations are challenging. The market has a different cost base to other airline sectors, so we need to be getting the most out of our fleet at all times.” Current destinations include Amsterdam, Berlin, Faro, Florence, Mykonos and Palma, to name but a few.

Efficient fleet planning

Of course, high utilization means the aircraft, and, in particular, their CF34 engines need to be performing at all times. In an industry where safety has the highest priority, maintenance is heavily-regulated and mandated for the engine’s life-limited



parts. But Leather also places importance on the efficiency of the engines. “Our biggest challenge is achieving maintenance in the most cost-effective way and in an optimal timeframe, both in terms of shop visit turnaround time and fleet planning,” he says. “MTU Maintenance has been excellent in this regard; helping us prolong time on wing and coming up with flexible cost-reduction strategies.”

In fact, MTU Maintenance celebrated its 1,000th CF34 shop visit at the end of June—and the engine belonged to the BA City-Flyer fleet. The engine was returned to Leather and his team in a celebratory ceremony with employees at MTU Maintenance Berlin Brandenburg. “It was a real privilege to be invited and be part of it, we’re really glad our engine was the 1,000th,” Leather says. But he wasn’t the only special guest at the event, the weather also made an impressive appearance: “I’ve never seen so much rain in my life. And I come from Manchester!” Leather exclaims. While he was visiting, around 150 liters per square meter fell from the skies in 24 hours, as recorded in Berlin—over 25 percent of the yearly average of 580 liters that is expected there. Despite its best efforts, the rain couldn’t dampen the celebratory atmosphere or the companies’ partnership though. “MTU Maintenance always goes the extra mile for us, so we were more than happy to put up with a little bit of water for them,” Leather says. 🌧️

Inside MTU — CF34-Familie



Queuing up — CF34 engines in the test cell rigging shop at MTU Maintenance Berlin-Brandenburg.

MTU Maintenance has been maintaining engines from the CF34 family (CF34–3, -8C/E, -10E) for 15 years and has provided MRO services to over 90 customers across the globe. The maintenance division of MTU Aero engines is a GE authorized service provider and services are performed at MTU Maintenance Berlin-Brandenburg. In addition to comprehensive MRO support, the MTU on-site support teams have enabled customers to avoid over 650 shop visits through their on-wing services since 2003. Support options were further enhanced in 2016, when MTU Maintenance Lease Services and Embraer Aviation International SAS joined forces to provide customers with comprehensive CF34-10E spare engine support. MTU Maintenance performs over 100 off-wing shop visits per year.



Do you have any questions, requests or suggestions?
Contact the editors here: aeroreport@mtu.de



More on this topic: www.aeroreport.de



Text:

Victoria Nicholls is a specialist for aftermarket topics such as engine MRO, leasing and asset management, as well as international market trends. The British-born editor lives in Berlin and works for MTU’s corporate communications in Hannover and Ludwigsfelde.

A collaboration of trust



When there are heavy loads to be transported, or troops to be landed in hard-to-reach areas, a high-performance helicopter is an absolute must. For 45 years now, the German Armed Forces have been successfully operating the Sikorsky CH-53G transport helicopter. And throughout, MTU Aero Engines and its predecessor companies have been at their side to take expert care of engine maintenance. Here's to decades of successful collaboration.

Text: Nicole Geffert



T64 ____ The turboshaft engine with a maximum thrust of 3,229 kilowatts that powers medium-size transport helicopters, such as the Sikorsky CH-53, was built between 1968 and 1975. At its Munich site, MTU carried out assembly and acceptance test runs for this engine manufactured in cooperation with GE and Klöckner-Humboldt-Deutz (KHD). Today, MTU's T64 activities focus on on maintenance. In 2014, the program to upgrade the T64-7 engines to the enhanced T64-100 standard was completed. The Bundeswehr collected the last T64 from MTU in—what else?—a CH-53G (picture on left).



Helicopter manufacturer Sikorsky first developed the CH-53 in the early 1960s for the use of the U.S. Marine Corps, with the first prototype taking off on October 14, 1964. It was a time of rapidly expanding transportation requirements for the German Armed Forces, and the old fleet simply couldn't keep up. It became clear that the German Armed Forces were going to have to procure a new model, and in the end they opted for the CH-53, powered by two General Electric (GE Aviation) T64 engines. On July 26, 1972, the German Armed Forces officially took delivery of the first "medium-duty transport helicopters" (MTH) from an overall order of 112 aircraft. Though first delivered to the Army Aviation Corps, the aircraft have been operated by the German Air Force since 2010 following the reshuffle of the German Armed Forces.

From the beginning, MTU was on hand to ensure the safe operation of the T64 engines, which were produced between 1970 and 1975 in a collaboration between GE Aviation and Klöckner-Humboldt-Deutz. In Munich, MTU was chiefly responsible for assembly and acceptance testing, and a total of 247 T64 engines were delivered. "These days, our work on the T64 focuses on maintenance. In the average year, 20 of these engines come through our doors for technical monitoring, repair or general overhaul," says Florian Pulfer, Head of Program Management for Helicopter Engines—Service & Maintenance at MTU.

Adapting to changing operating environments

Over 45 years of service, missions and requirements have changed. The CH-53G and its T64 engines have had to be modified and developed to equip them for extreme weather conditions and geographical locations. In close consultation with the German Armed Forces, this led to the launch of an upgrade program for the CH-53G. By 2014, 166 engines had been brought up to date in collaboration with the German Armed Forces.

The upgrade encompassed almost a dozen components, from the fuel pump and fuel regulator to the combustor inserts and gas generator turbine. The upgraded T64-7 became the T64-100, with a maximum power output of 3,229 kilowatts—300 kilowatts more than its predecessor. This boost was achieved by installing newly developed turbine blades that allowed for an increased combustion temperature. In addition, the helicopters were equipped with sand filters to minimize the wear resulting from sand ingestion. The German Armed Forces leapt at the opportunity to collect the last of the 166 upgraded engines directly from MTU in Munich in November 2014—in a CH-53G, of course.

100,000 flight hours

The German Air Force plans to continue operating the CH-53 fleet until 2030: "The team at MTU has done everything to ensure that the engines will be able to carry out their tasks efficiently and reliably well into the future," says Wolfgang Gärtner, head of Helicopter Engine Programs at MTU. The best demonstration of this is the fact that the T64-100 reached the 100,000 flight hours mark on June 18, 2017.

The decades of trustworthy collaboration have extended to other military programs, and MTU employees work shoulder to shoulder with German soldiers on engine maintenance in a variety of collaborations. The idea was first developed and implemented by MTU together with the Bundeswehr—the first of its kind. Since the model proved so effective for the Eurofighter EJ200 engine, it was rolled out to other military engine programs, including the RB199 Tornado engine and the MTR390 powering the Tiger combat helicopter. The model saves money and time by pooling resources, and ensures the best possible provision of service-ready engines for the troops that need them.

As Klaus Günther, Head of Military Programs at MTU, comments: "The German Armed Forces can rely on MTU at all times to provide innovative maintenance and repair techniques and personal customer service." 



Do you have any questions, requests or suggestions?
Contact the editors here: aeroreport@mtu.de



More on this topic: www.aeroreport.de



Text:
Nicole Geffert has been working as a freelance journalist covering topics such as research and science, money and taxes, and education and careers since 1999.



“The future is geared”

Dr. Frank Grauer, MTU’s Director Engineering Advanced Programs, talks about hot topics and the future at this year’s International Society of Air Breathing Engines (ISABE) conference, an opportunity for experts from around the world to discuss the field of air-breathing propulsion.

Text: Eleonore Föhling



Dr. Frank Grauer has been Director Engineering Advanced Programs for commercial and military propulsion systems at MTU Aero Engines since 2015. He joined MTU in 1999, working on various technology and development projects, including the TP400-D6 engine that powers the A400M. In 1998, he was awarded a doctorate from the Ruhr University Bochum for his work on active stability control in axial compressors.

Dr. Grauer, you represented MTU Aero Engines as a keynote speaker at the 23rd ISABE conference in Manchester in September. What was your talk about?

Dr. Frank Grauer: My talk was about the fundamental challenges facing the aviation industry with respect to the ambitious targets set for 2050, and MTU’s strategy for helping achieve them. I am of course referring to our Claire roadmap, which stands for Clean Air Engine. I focused my attention on the period after 2030, because I wanted to highlight that we need to lay the technological foundations today.

Electric flight is a hot topic of conversation at the moment. But when you get into it, you quickly realize that the contribution electric propulsion systems make to achieving the 2050 climate goals will be modest, to say the least. It’s a question of coming up with alternatives. On the national and European level, there are a range of ideas out there as to how to optimize gas turbines to meet the 2050 targets. However, these ideas are not being marketed to the public as aggressively as electric flight. The

“I was delighted to see many speakers describe the Geared Turbofan™ as an extremely innovative and leading solution. ‘The future is geared’ is a phrase I heard many times”

reality is that bigger passenger aircraft are going to rely on gas turbines for a long time to come—either to power the aircraft or, if it proves an effective strategy, to generate electricity as part of a hybrid propulsion system. In other words, we’re still going to need air-breathing engines in 2050, and that means continuing to work on optimizing them.

With the world’s aero engine experts in research and industry all in one place for a whole week, what discussions did you have in the course of the events?

Grauer: Naturally we discussed a whole range of topics. Aside from electric flight, much of the discussion was about the same topics as are on the agenda here at MTU: digitalization, simulation in production and development, and additive manufacturing. The potential of ceramic matrix composites (CMCs) came up again and again. I was delighted to see many speakers describe the Geared Turbofan™ as an extremely innovative and leading solution. “The future is geared” is a phrase I heard many times.



Which of your colleagues' talks and ideas were you the most excited about?

Grauer: Personally speaking, I was of course extremely excited to see how my MTU colleagues would get on. There were a total of three talks by other MTU representatives. The first explored the variable cycle engine with a focus on the factors to be taken into account in the preliminary design phase. Another presented a technique for factoring in erosion in the fan and compressor at an early stage of the design process. This is an important consideration if you want to think about the maintenance costs early on. And finally, the third presentation gave an excellent overview of the progress so far in the EU-sponsored ENOVAL project, which MTU coordinates. All three talks were delivered to a packed room and were followed by lively debate. Well executed and well received, in my opinion.

Apart from that, I found many of the keynotes interesting and they gave me an overview of what the competition is doing. I was struck by the fact that the excitement surrounding electric flight does seem to have receded a bit. People are slowly calm-

ing down and being realistic about the potential applications and timescale involved.

What else did I find interesting? Perhaps the fact that additive manufacturing is the term on everybody's lips and that many people are realizing the potential offered by simulation in production. Then there were Airbus's extremely innovative ideas for urban mobility, which have really caught the imagination. And Safran's announcement that it will not be going ahead after all with its flight testing of the Open Rotor as part of Clean Sky as planned.

Another talk I found fascinating was EasyJet's presentation on the airline's selection process for the successor to the A320ceo. This was divided into two parts: First, the choice of aircraft between Boeing and Airbus, and then, once the decision had been taken to go with the A320 family, the engine selection process, which went in favor of the LEAP.

“For us, that means that we will continue to work with our partner Pratt & Whitney to improve the Geared Turbofan™. We want to work with aircraft manufacturers to achieve even better bypass ratios so that we can make more use of the theoretical advantages offered by the GTF concept.”

Dr. Frank Grauer,

Director Engineering Advanced Programs for commercial and military propulsion systems at MTU Aero Engines

What engine technologies for the future are researchers exploring at the moment?

Grauer: If we're talking about the next generation of aircraft, for instance a successor to the A320 around 2030, it's primarily a case of making developments that build on current concepts. For us, that means that we will continue to work with our partner Pratt & Whitney to improve the geared turbofan. We want to work with aircraft manufacturers to achieve even better bypass ratios so that we can make more use of the theoretical advantages offered by the GTF concept. Here, the way the engine is integrated into the aircraft plays a significant role.

As far as our competitors are concerned, they should see this as a sign that “the future is geared” and make their own efforts to embrace the GTF and gather their own experience in this area.

What about the period up to 2050?

Grauer: That's still a very open question. Clearly, thinking is tending towards disruptive concepts that will improve engines' thermal efficiency. Currently, there are a wide range of national and European projects examining and evaluating enhancements to cycle processes. One of the most popular concepts is

what is known as a composite cycle engine, in which the thermodynamic cycle can be significantly optimized using an additional piston engine component. Incidentally, that idea can be traced back to an MTU patent and is currently being examined by numerous universities and research institutes.

All of these ideas give rise to the question of whether the potential that is undoubtedly there can be effectively harnessed. For instance, weight and reliability will always play a critical role in aviation. We are only in the early stages in this regard, and still need to come up with some good ideas. We are directly involved in the important studies so that we can fulfill our role as drivers of innovation in the aviation sector and, at the same time, identify future development trends and technology demands.

What's new with regard to electric engine concepts?

Grauer: It is becoming increasingly obvious that all-electric engines, that is to say fan engines powered solely by batteries, will remain, at best, restricted to small-scale applications and short-range journeys for the foreseeable future. These are exactly the applications being targeted by Airbus with its ideas for urban mobility, for instance.

Dr. Frank Grauer _____
Aircraft engines that are to meet the 2050 climate goals need revolutionary concepts, he says.



As far as high-volume passenger flights are concerned, the community is focusing on turbo-electric systems. Here, a gas turbine generates electricity that is distributed to multiple fan engines around the aircraft via a smart system of on-board electronics. The key concern is the impact that this has on the whole. On the plus side, we can expect benefits resulting from boundary layer suction, improvements to wing aerodynamics, and even perhaps the omission of control surfaces. On the other hand, these sorts of systems add complexity and weight. It's something we will have to look at in depth. We are working on these studies with a range of partners such as Airbus, Siemens, and Bauhaus Luftfahrt, for instance in the EU-sponsored CENTRELINE project, so that we can build on our understanding in this area and spot any trends at the earliest opportunity.

What does the industry need?

Grauer: Innovative and creative minds with the ability to develop key mainstream technologies such as heat-resistant, lightweight materials as well as industrialize new production techniques such as additive manufacturing. Expanding on simulation techniques is also a part of the puzzle.

Has the next generation's time come, then, within the aero engine industry?

Grauer: Certainly, we have a lot of exciting topics for young engineers to get their teeth into. There is a huge opportunity for them over the coming years. After all, if we are to build aero engines that can meet the 2050 climate targets, we are going to have to move away from our traditional evolutionary approach and find completely new, revolutionary concepts. 



Do you have any questions, requests or suggestions?
 Contact the editors here: aeroreport@mtu.de



More on this topic: www.aeroreport.de



Text:
Eleonore Föhling is MTU's Editor in Chief for **AEROREPORT** and has been in charge of the MTU employee magazine since 1999.

Working together around the globe

Dr. Rainer Walther, Administrative Secretary of the International Society of Air Breathing Engines (ISABE) since 2013, discusses its objectives and topics.

Text: Eleonore Fähling





Dr. Rainer Walther ——— *Administrative Secretary of the International Society of Air Breathing Engines (ISABE) since 2013.*

Dr. Rainer Walther until recently worked in technology development at MTU Aero Engines as coordinator of technology networks with research institutions and universities. From 1985, he worked in various areas of R&D at MTU. In 1985, he obtained a doctorate in aviation and aerospace engineering at the University of Stuttgart, where after graduating he held a post as research associate. Since 1993, he has been an assistant lecturer there and was granted an honorary professorship in 2001.

In 2003, Walther was elected Vice President of the International Society of Air Breathing Engines (ISABE). In 2006, he was appointed to ISABE's Board of international representatives as Germany's second National Representative and has been the organization's Administrative Secretary since 2013.

Dr. Walther, what does your job as Administrative Secretary of the ISABE entail and how did you come to obtain this post?

Dr. Rainer Walther: My tasks as Administrative Secretary are very multifaceted. They include, for example, choosing attractive venues for the ISABE Conferences held every two years, as well as planning and organizing them together with ISABE's Board of Directors and National Representatives. Recently, we chose Canberra, Australia, as the location for the next conference in 2019. In addition to this, I support the local organizational committees with selecting speakers and deciding on the themes of the conferences.

I've personally always been passionate about attending the ISABE Conferences, which I've participated in regularly and actively for more than two decades. In 2003, I was elected Vice President of ISABE. That involved organizing and hosting the 17th ISABE Conference in Munich in 2005 which, thanks to the great support from MTU and many of my colleagues, was an unforgettable success.

ISABE was formed over 40 years ago when the industry giants were still paralyzed by the Cold War, and when the Concorde and Tupolev Tu-144 were the aviation technology flagships of the superpower blocs. Given those circumstances, how was it possible to discuss technology development at a global level?

Walther: The first ISABE Conference was held in Marseille in 1972. Granted, an open international exchange of knowledge in the field of air-breathing engine technology certainly wasn't easy in those days. However, even then, an exchange of research and development findings took place not only between industrial enterprises, but also between internationally recognized large research centers such as America's NASA, Canada's NRC, Russia's CIAM, France's ONERA and Germany's DLR. In the early years, there were only around 100 conference participants, far fewer than there are today. This year's 23rd ISABE Conference in Manchester, UK, in September attracted some 400 experts; in Munich in 2005 around 500 people attended.

“Looking forward, it’s my belief that aspects of engine-airframe integration will increasingly take center stage in presentations and discussions with airframe developers at ISABE Conferences.”



What propulsion technologies of the future are engineers and companies in the aero engine industry working on today?

Walther: The presentations given at the ISABE Conference today focus on cost-effective, fuel-efficient and low-emission engines and components. Examples include Geared Turbofan™ engines, open-rotor engines and, with a more long-term perspective, electric and hybrid engine concepts. Other topics addressing the latest developments and applications for advanced manufacturing technologies such as additive manufacturing are also raised and discussed at length.

This year, I was surprised by the level of enthusiasm and untiring commitment with which representatives reported on extensive research and development work in the field of air-breathing engines for hypersonic propulsion systems—notably from a number of Asian countries.

What will an ISABE Conference be like ten years from now?

Walther: Looking forward, it’s my belief that aspects of engine-airframe integration will increasingly take center stage in presentations and discussions with airframe developers at ISABE Conferences. The reason is that with the potential application of future open-rotor and hybrid powerplants, their integration into the airframe will play an important role in ensuring synergies between the engine and airframe are leveraged to their full potential.

Apart from this, I think the number and diversity of conference papers, especially from Asian countries, will continue to increase. We will also see interest in the conference grow in countries with little or no representation to date. This year, for example, Kenya was the 29th nation to be granted ISABE membership. 



Do you have any questions, requests or suggestions?
Contact the editors here: aeroreport@mtu.de



More on this topic: www.aeroreport.de



Text:
Eleonore Föhling is MTU’s Editor in Chief for **AEROREPORT** and has been in charge of the MTU employee magazine since 1999.

A well-grounded assembly system

From the initial idea to industrial maturity: MTU's unique final assembly line for the PW1100G-JM engine powering the A320neo.

Text: Silke Hansen

Sure, MTU Aero Engines is a vital player in the engine industry; its products are key aero engine technologies. The best example is the high-speed, low-pressure turbine for the Geared Turbofan™, which has received two awards for its innovative technologies. MTU's expertise extends much further, however, as the system developed in-house for the final assembly of the PW1100G-JM engine that powers the A320neo demonstrates—sophisticated production technology that is unmatched anywhere in the world. As is so often the case—and this is no exception—it's the people with their ideas, their energy, their expertise and a measure of courage to take a risk who are driving the new solutions forward.

Floor-based not crane-based

With the final assembly line for the A320neo powerplant, that person was

Elmar Stichlmair who at MTU heads up PW1100G-JM industrialization. In September 2011, MTU was awarded the contract by U.S. cooperation partner and OEM Pratt & Whitney to assemble 30 percent of all PW1100G-JM engines. That was quite a challenge in itself, since this was the first time MTU had been responsible for the final assembly of a commercial engine in such large numbers. The whole assembly line had to be completely reconfigured, with the proviso that it should take up as little floor space as possible and, most importantly, offer a high degree of flexibility. Engines are normally assembled at several fixed assembly stations using cranes that run on rails suspended from the ceiling. "I had the idea to organize the assembly process using a floor-based system," Stichlmair explains. He had previously helped to mastermind the highly automated line for the GEnx

turbine center frame, which he saw as a model for his idea.

It soon became clear that the engine would travel along the main assembly line in a cart. "However, this would have had to be so large that team would not have been able to reach the engine." And so the multiple cart concept was born. The MTU project manager continued refining the design. "The idea matured slowly." The result is a system of up to 16 carts which, coupled together depending on the stage of assembly, move forward along the line in a similar way to a conveyor belt.

The employees assemble the engine in eight main steps—some vertical, some horizontal—inspect it, pack it up and ship it. Pre-assembly of the modules, which dovetail in from the sides, is carried out in parallel to the actual engine assembly.

“What’s more, the whole thing worked like clockwork from the get-go. Everything was a perfect fit.”

Elmar Stichlmair,
MTU heads up PW1100G-JM industrialization

This makes the system especially efficient because it allows the team to work on multiple engines at different stages of completion at the same time—and from 2019 capacity is set to reach one engine a day.

In-house solution wins through

One major challenge in terms of planning was that at the time, MTU had no documentation relating to the engine as a whole or its overall dimensions. The engine was still in the development stage and, as a specialized supplier, MTU is responsible only for individual modules. Eventually, Stichlmair was able to obtain a first set of specifications on paper. Now all that remained was to make the concept a reality. In the tender for the design and construction of the carts and fixtures, it was MTU’s in-house tooling and plant service team that came up with the winning concept. “What’s more, the whole thing worked like clockwork from the get-go.

Everything was a perfect fit,” Stichlmair says, clearly still in awe of the feat his colleagues pulled off. With the detailed planning that followed, the PW1100G-JM Assembly & Test project got underway. Stichlmair headed up the project team of 100 employees and organized collaboration among the departments involved and the coordination with Pratt & Whitney.

Success without a plan B

In May of last year, the first engine on which the processes were to be tested arrived in Munich from the United States. The system worked without a hitch from the very beginning. Just as well, because there wasn’t a plan B. In early August, auditors from the Federal Aviation Administration (FAA), the U.S. aviation authority, visited Munich. They gave the new assembly concept the go-ahead. With that major hurdle cleared, things started happening really fast. In late August 2016, MTU completed assembly of the

first production engine and delivered it to Airbus in Toulouse. Two months later, MTU officially inaugurated its assembly line—marking another milestone in the company’s history. It was a standout moment for Stichlmair, too, who admits to feeling proud. His faith in MTU was well-placed. The company now operates one of only three final assembly lines for the PW1100G-JM engine worldwide. This is the most important engine program for MTU’s future—and the order books are bulging.

The system has in the meantime been patented and Stichlmair and six other colleagues have received an MTU award for their achievements. “It was an extremely busy time involving many interesting as well as complex issues—and the occasional glitch along the way. But it was worth it. And the end result is an excellent product. Yet again.



Do you have any questions, requests or suggestions?
Contact the editors here: aeroreport@mtu.de



More on this topic: www.aeroreport.de



Text:

Silke Hansen writes for **AEROREPORT** as a freelance journalist. For over ten years, she has covered the world of aviation, focusing on technology, innovation and the market. Corporate responsibility reporting is another of her areas of specialization.



As fascinating as ever _____ *The Concorde
supersonic passenger jet had its first flight in 1969.*

Wanted: The next generation of supersonic

Concorde is history, but what about the future of high-speed passenger flights? A company from Denver plans to offer supersonic flights starting in 2023.

Text: *Andreas Spaeth*



MILESTONES OF SUPERSONIC FLIGHT

- October 14, 1947**
 Captain Chuck Yeager becomes the first human to break the sound barrier in his Bell X-1, reaching-Mach 1.06
- November 1962**
 Concorde program is launched
- June 5, 1963**
 U.S. President John F. Kennedy announces the launch of an American supersonic program, which later becomes the Boeing 2707
- July 26, 1963**
 The Soviet Union launches development of the Tupolev Tu-144 supersonic airliner
- October 3, 1967**
 The hypersonic rocket-powered X-15 aircraft reaches Mach 6.72 (7,224 km per hour) at an altitude of 31,120 meters, a world record for a manned aircraft, which still stands today
- December 31, 1968**
 First flight of Tupolev Tu-144
- March 2, 1969**
 First flight of the Concorde
- May 20, 1971**
 Boeing's supersonic program is cancelled
- January 21, 1976**
 Air France and British Airways launch scheduled Concorde flights
- November 1, 1977**
 Aeroflot launches scheduled Tu-144 flights
- June 1, 1978**
 55th and last scheduled flight of the Tupolev Tu-144
- November 26, 2003**
 Last-ever flight of the Concorde, from London Heathrow to a museum in Bristol, UK

At the Musée de l'Air on the grounds of Le Bourget airport in Paris, the past and the future of supersonic flight meet, 70 years after Chuck Yeager became the first human to break the sound barrier in October 1947, and about 48 years after Concorde's first flight. A prototype of the jet is on display here, alongside a production aircraft, which carried fare-paying passengers along the edge of space at a speed of Mach 2.02 from 1976 to 2003. Blake Scholl is awestruck as he walks through the cabin of the Air France Concorde on display. The 36-year-old American from Denver is attempting to launch a new era of supersonic passenger flights very soon. "Unfortunately I never flew on Concorde myself; I was only 23 years old when it ceased operations," he regrets.

He holds his hand against one of the windows and is able to cover it almost entirely with just his palm. At the time, the fuselage was made of aluminum, meaning that the windows had to be built almost like peepholes for structural reasons. In flight, they turned as hot as stove tops due to the frictional heat. "It's incredible how small they are. In our aircraft, thanks to composite materials replacing aluminum, we will have much bigger windows," explains the start-up entrepreneur. He looks at the seats of the narrow Air France cabin: "These days this is Premium Economy standard at best. We will improve the cabin comfort considerably," promises Blake Scholl. 55 reclining lie-flat business class seats will be fitted to the Boom Passenger Airliner, or even 15 full-flat seats in First plus 30 in Business. Pure luxury compared to Concorde.

Challenging technics and economics

There have always been bold plans for new supersonic concepts, but nobody was able to overcome the extreme hurdles coming with them. Minimizing sonic boom, containing engine noise and enabling economically sustainable operations at the same time—the technological and financial challenges are huge. Smaller supersonic business jets are so far regarded as the best bet. Their slim fuselage is minimizes the sonic boom, and top managers or stars in a hurry don't fly on a tight budget. In 2014, an early project for a twelve-seater called Aerion was unveiled. Even Airbus was involved, but progress is slow. Much like Boom, a Boston-based start-up plans to launch its 18-seater Spike S-512 by 2023. Nasa is partnering with Lockheed Martin to build a demonstrator, slated to take to the skies by 2021. Ultimately, the quiet 80-seater jet is set to be less than half the size of Concorde and to fly slightly slower—at Mach 1.7.

Boom is the only project taking on the challenge to build a bigger passenger jet within a short time-frame. The first milestone will be the launch of the twin-seat demonstrator XB-1 by the end of 2018, nicknamed Baby Boom. The fastest civil aircraft is set to reach Mach 2.2 (2,325 kilometers per hour), flying more than twice as fast as the speed of sound, exactly like the production aircraft later. But independent scientists have reservations: "I believe the goals of Boom are overambitious," warns Dr. Bernd Liebhart of the Institution for Air Transportation Systems at the German Aerospace Center (DLR) in Hamburg. "The speed they are aiming for, Mach 2.2, is quite high, Mach 1.4

CONCORDE AND ITS POSSIBLE SUCCESSORS

	Concorde	Boom	Aerion	Spike
Length	62.13m	51.80m	52m	37m
Wing span	25.56m	18.20m	19m	17.70m
Engines	4	3	3	2
Passengers	100	55	8-12	18
Range	6,230 km	8,334 km	8,797 km	10,334 km
Speed	Mach 2.02	Mach 2.2	Mach 1.5	Mach 1.6
First flight	March 2, 1969	2023	2018-2021	after 2020

How fast is supersonic?

Speeds greater than the speed of sound are given in Mach—after the Austrian physicist Ernst Mach (1838-1916). The Mach number (M or Ma) expresses the ratio of velocity (v) to the speed of sound (c): $M = v/c$. The speed of sound varies depending on temperature and atmospheric pressure. At a temperature of -50°C and an atmospheric pressure of 26 kilopascals at an altitude of 10,000 meters, the speed of sound is approximately 300 meters per second. An aircraft flying at Mach 1 is therefore travelling at 1,080 kilometers an hour.

or 1.6 as in other projects appears to be more realistic. Engines laid out for Mach 2.2 will be so noisy at take-off they are unlikely to be certified. In addition, the Boom jet – with 55 seats—is fairly large. However, it will be difficult to find enough destinations or sufficiently wealthy passengers for it.”

Skeptical experts

Also at MTU, there is scepticism: “I think, Boom’s goal to fly by 2023 is unrealistic. Adaptation and integration even of an existing turbofan engine into such an aircraft will take at least six years,” says Bernhard Köppel, Senior Manager Flight Physics & Operating Cost Analysis for New Programs at MTU in Munich. “And when you want to fly Mach 2.2 instead of Mach 1.5 it doesn’t give you a big advantage, but rather creates big difficulties for example with fuel burn and noise emissions,” according to Köppel. DLR engineer Bernd Liebhardt estimates the chances of having supersonic passenger flights in ten years from now at below 50 percent as, since Concorde, nobody has dared to take the decisive step of starting an industrial development program. But, says Liebhardt, “to construct such an aircraft is a huge inspiration for generations of engineers, it is the most formidable challenge in all of aviation.” 

THE SUPERSONIC JETS OF TOMORROW



Boom Supersonic _____ The start-up by former Amazon executive Blake Scholl plans to get its “Baby Boom” two-seater (pictured above) airborne by 2018; when completed at a later date, the Boom passenger airliner (below) will have 55 business class seats.



Aerion _____ The maiden flight of the twelve-seat ultrasonic private jet, for which Airbus is a partner, is planned for between 2018 and 2021.



Spike _____ The Boston-based start-up’s 18-seater is due to launch in 2023.



Do you have any questions, requests or suggestions?
Contact the editors here: aeroreport@mtu.de



An in-depth interview with Blake Scholl, CEO of Boom Supersonic, is available at: www.aeroreport.de



Text:
Andreas Spaeth has been traveling the world as a freelance aviation journalist for over 25 years, visiting and writing about airlines and airports. He is frequently invited to appear on radio and TV programs.

From automobile mechanic to aviation pioneer



*100th birthday and 20th anniversary of the death of the “Elder Statesman of Aviation”
Gerhard Neumann (1917-1997)*

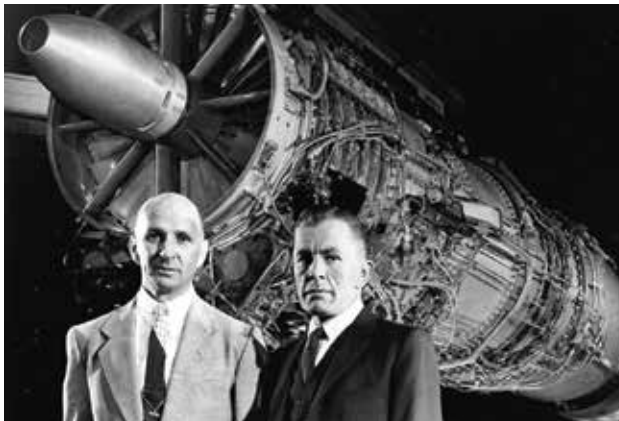

Legends _____ Gerhard Neumann (left) and Neil Burgess developed the J79 engine (in the background).

Born on **October 8, 1917** in Frankfurt an der Oder, Germany, Gerhard Neumann was fascinated by flying from an early age: when he was just 15, he built a glider—and flew in it.

After completing an automotive mechanic apprenticeship, followed by engineering studies and a stint with the U.S. voluntary corps “Flying Tigers” in China, he emigrated to Lynn, Massachusetts. In **1948**, he landed a job as a test engineer for axial engines at General Electric.

He experimented with an engine compressor with variable stators that could adapt to the direction of airflow. This concept greatly improved its overall performance and is now standard

in almost all engines. The construction patent bears Neumann’s name. Seven more patents were to follow in the course of his career.

From **1955**, the variable stators on seven out of 17 compressor stages in the **J79** (used to power the **F-4 Phantom II** and **F-104 Starfighter** among others) went into production. With over **19,000** J79s produced, this was Neumann’s most successful engine program.

In the meantime, Neumann became general manager for GE’s jet engine business and from **1961** he developed an innovative high-bypass engine: only a small volume of the air ingested by the fan flows through the compressor, combustor and turbine. Most of it bypasses the core engine. This marked the birth hour of the **high bypass ratio**, bringing enormous reductions in fuel consumption and noise. The concept gave rise to the **CF6**. For the aviation industry, this marked the beginning of the age of widebody aircraft. And, of course, the variable stators were part of the concept, too.

Contemporaries recount that behind Neumann’s desk there was a sign which read “Feel insecure”. Only then are we open to change and innovation. Through to retirement, Neumann would test GE’s products himself from the cockpit.

“The harder I work, the happier I am,” was Neumann’s motto in life. However, this attitude also took its toll on his health. Several times, he had to undergo heart surgery. He retired in **1980**, aged 63. He died 17 years later on November 2, 1997, shortly after his 80th birthday.

Big and efficient

At GE Aviation, the GE9X for the Boeing 777X is nearly ready for its first flight

3.4 meters

134 inches—or 340.36 centimeters—is the diameter of the fan case

16 blades

The carbon fiber composite fan consists of **16 blades**—no widebody engine on the market today has fewer.

Program launch: 2017

GE is planning to launch **the GE9X flight test campaign** in late 2017.

Pressure ratio: 27:1

An **11-stage high-pressure compressor** achieves a pressure ratio of 27:1—according to GE Aviation “the highest in aviation history”. The engine’s overall pressure ratio is 60:1.

Lightweight & extremely robust

The **low-pressure turbine blades** manufactured from titanium aluminide are lightweight and extremely strong.

TCF serves as a duct for hot gases up to 1,000 °C

MTU Aero Engines develops and manufactures the GE9X **turbine center frame (TCF)**. The component directs the hot gas flows with temperatures of up to 1,000 degrees Celsius from the high-pressure turbine past structural components and cables to the low-pressure turbine—with minimum aerodynamic losses.

Ten percent less fuel

The GE9X is designed to **reduce kerosene consumption by ten percent** compared with its predecessor, the GE90-115B.

MTU CONTRIBUTES HIGHLY ENGINEERED COMPONENT / FOUR-PERCENT WORKSHARE IN THE GE9X

MTU has taken a **four-percent** share in the **GE9X** program, assuming design, development and production responsibility for the turbine center frame – a highly engineered component. The first development module was delivered to GE in January 2016. MTU has many years of experience with this part, which it already contributes to the GP7000 (Airbus A380) and the GENx (Boeing 787 Dreamliner, 747-8) engine programs.

BOEING 777X



The Boeing 777X widebody aircraft is set to take to the skies in 2020, powered by **GE9X** engines.

An aircraft's eyes and ears

Sensors and systems work together to ensure a safe flight

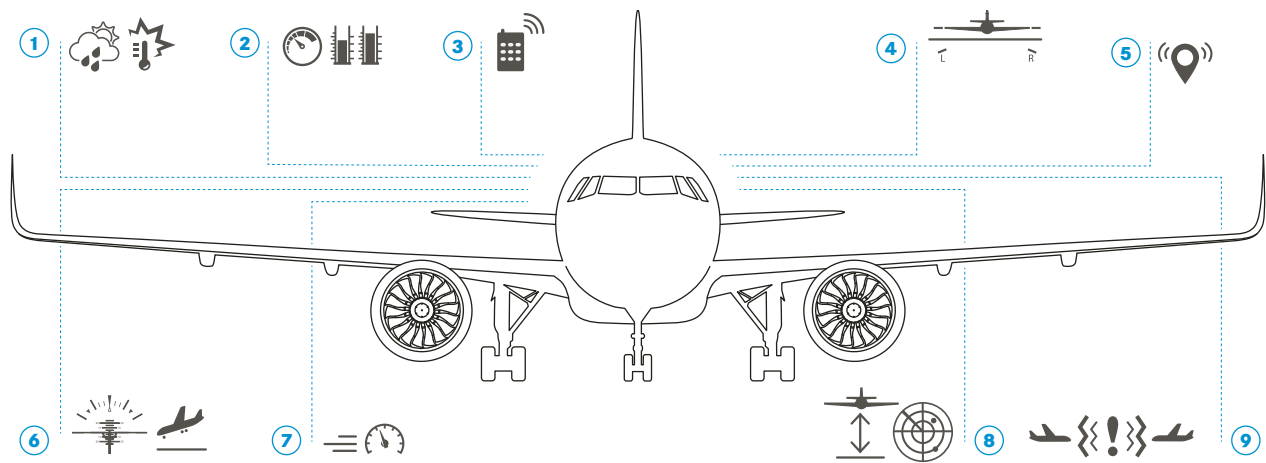

1 Airborne weather radar _____ The weather radar is usually built into the nose of the aircraft within a protective enclosure known as a radome. Its purpose is to monitor the local weather and give pilots early warning of any dangerous weather events.

2 ECAM (Electronic Centralized Aircraft Monitoring) _____ In Airbus aircraft, this electronic system displays the most critical engine parameters and monitors all of the aircraft systems—fuel and hydraulics, for instance. It also reports any errors and suggests solutions for resolving them. Boeing operates a similar system known as EICAS (Engine Indication and Crew Alerting System).

3 Aircraft radio _____ Pilots and air traffic controllers communicate via radio transmissions at set frequencies according to strict guidelines and prescribed formulations. This high level of standardization is for safety reasons, as it helps avoid miscommunication.

4 Attitude and bank and turn indicators _____ The attitude indicator, also known as the artificial horizon, shows pilots the orientation of their aircraft relative to the Earth's surface. Meanwhile, the bank and turn indicator shows the angle of the aircraft with respect to horizontal axis and the rate of turn.

5 GPS (Global Positioning System) receivers _____ Aircraft use GPS receivers to determine their position. The data comes from GPS satellites that send out regular signals specifying their position at a given moment in time.

6 ILS (Instrument Landing System) receivers _____ The ground-based instrument landing system helps pilots as they approach to land. An ILS receiver on board the aircraft processes two guidance radio signals to determine the course (direction) and glide path (altitude) for landing. This enables pilots to land with precision even when visibility is poor.

7 Pitot tube _____ A Pitot tube is an instrument used to calculate an aircraft's airspeed. It works by collecting air so as to determine stagnation pressure. When you subtract the static pressure from the stagnation pressure, you are left with the dynamic pressure. And once you know the dynamic pressure, you can use the atmospheric density to calculate airspeed and thereby the speed of the aircraft.

8 Radar altimeter _____ A radar altimeter measures the aircraft's exact altitude above the ground using short electromagnetic waves.

9 TCAS (Traffic Alert and Collision Avoidance System) _____ The TCAS is an on-board early warning system that helps avoid air collisions. If two aircraft are on a collision course, it will show both pilots how to adjust their course so as to avert an impending collision.

30 years of the V2500

*Facts and figures about the successful
A320, MD90 and KC390 engine*



100 million is the number of flight cycles completed by V2500 engines between their first test run in 1987 and the summer of 2017. A flight cycle comprises take-off, ascent, cruising, descent and landing.

500,000 flight hours is the milestone reached by V2500 engines in 1992. By 1995, this figure had risen to **five million**. The V2500 fleet broke the **100 million flight hour** mark in 2011.

25,000 pounds of thrust was generated by the first version of the V2500—the A1 series. That is the equivalent of 110 kilonewtons. The latest and most powerful version, the V2500-E5 for Brazilian airframer Embraer's KC-390 military transport aircraft, supplies 32,000 pounds or 139 kilonewtons of thrust.

Over 7,300 V2500 engines have been delivered to customers since the first were commissioned. They are in service with 160 airlines in 80 countries worldwide.

5 is the number of founding members of the International Aero Engines (IAE) Corporation. In 1983, Pratt & Whitney, Rolls-Royce, Fiat Avio, Japanese Aero Engines Corporation and MTU joined forces in this consortium to develop an engine for single-aisle aircraft. Fiat and Rolls-Royce subsequently dropped out; MTU's share in the joint venture was increased to 16 percent.

Over 4,300 individual V2500 shop visits have been carried out by MTU Maintenance since 1989. As the majority of the V2500 fleet currently active worldwide is not yet older than nine years, those engines still have their first maintenance ahead of them. V2500 engines are maintained at MTU shops in Hannover, Zhuhai, and since recently also in Vancouver.

At a glance

GENx in numbers

3,000 individual parts are installed in the turbine center frame (TCF) of the GENx engine. MTU Aero Engines has a 6.65 percent workshare in the GENx program and is responsible for the development, manufacture, assembly and maintenance of this important component. The engine powers the Boeing 787 Dreamliner and the Boeing 747.

1,000,000 flight hours have been clocked up by GENx engines for the air freight company Cargolux. The airline from Luxembourg was the first in the world to reach this milestone. With entry into service of its first Boeing 747-8F more than five years ago, Cargolux also became the launch customer of the innovative GENx engine powering the jet. "This proves how outstanding the engine's technology and performance are," says Tom Levin, General Manager of the GENx program at GE Aviation.

Over 1,300 engines are currently in operation, powering aircraft for 51 different customers. The planned sales volume to the end of the GENx program is around 3,600 units. Since March 2017, the Turbine Center



Frame has been manufactured and assembled at the MTU site in Poland. The TCF has been repaired exclusively in Hannover since 2015—in other words, MTU covers the entire lifecycle of the component.

Free newsletter

Sign up for **AEROREPORT** as a newsletter! We send all the latest reports, background articles and news featured in **AEROREPORT** straight to your desktop or mobile device – it's completely free and you may unsubscribe at any time. To subscribe, simply visit the **AEROREPORT** website – and never miss out on a story again.

Sign up for the free newsletter at:

<https://www.aeroreport.de/en/newsletter>

AEROREPORT 02|17

Editor

MTU Aero Engines AG
Eckhard Zanger
Senior Vice President
Corporate Communications and Public Affairs

Managing editor

Dongyun Yang

Editor in chief

Eleonore Fähling

Print version

Antje Endter

Online version

Patricia Hebbing

Address

MTU Aero Engines AG
Dachauer Straße 665
80995 Munich, Germany
aeroreport@mtu.de
www.aeroreport.de

Editorial staff

Denis Dilba, Eleonore Fähling, Nicole Geffert,
Silke Hansen, Victoria Nicholls,
Thorsten Rienth, Andreas Spaeth

Layout

SPARKS CONSULTING GmbH, Munich

Photo credits

Cover MTU Aero Engines
2_3 MTU Aero Engines
6_7 MTU Aero Engines, Tina Rieger-Gudehus
8_15 MTU Aero Engines
16_19 Peter Diehl
20_23 MTU Aero Engines
24_27 Nick Morish, British Airways, MTU Aero Engines
28_29 MTU Aero Engines
30_35 MTU Aero Engines
36_39 MTU Aero Engines
42_45 plainpicture/Aviation/Mark Wagner,
Aerion Corporation, Spike Aerospace,
Boom Technology
46_52 GE Aviation, Josef Voggenreiter, MTU Aero Engines,
JetBlue Airways

Printed by

EBERL PRINT GmbH, Immenstadt

Online

ADVERMA
Advertising und Marketing GmbH, Rohrbach

Translation

Burton, Van Iersel & Whitney GmbH, Munich

Contributions credited to authors do not necessarily reflect the opinion of the editors. We will not be held responsible for unsolicited material. Reprinting of contributions is subject to the editors' approval.



LIFETIME EXCELLENCE

Welcome to a new era in commercial aviation: Geared Turbofan™ engines are quieter, cleaner and more efficient. The secret? MTU Aero Engines' unique high-speed low-pressure turbine. With innovative technologies, plus the highest-quality development, series production and aftermarket services, we are a strong partner to the aviation industry.

www.mtu.de



AEROREPORT

MTU Aero Engines AG, Dachauer Str. 665, 80995 Munich, Germany
aeroreport@mtu.de, www.aeroreport.de